

Sorrento 2TM

Instruction Manual

Terminologies

Patient

The person sitting in the chair.

User

Competent person with responsibility for the persons sitting in the chair as well as the suitability of the equipment for the Patient. The User is responsible for checking the chair for faults during the course of its use.

All instructions must be read and understood before the chair may be used.



Contents

2	Technical Specification
4	Operating Instructions
4	Tilt in Space (Manual Option)
5	Back Angle Adjustment (Manual Option)
6	Leg Elevation (Manual Option)
7	Back Height Adjustment
8	Seat Depth Adjustment
9	Seat Width Adjustment
10	Arm Removal
11	Arm Height Adjustment
12	Footplate Angle
13	Footplate Height
14	Seat Cushion
15	Chair Function (Motorised Option)
18	Chair Movement
20	Cleaning Instructions
21	Safety Instructions
22	Maintenance & Servicing
23	Recycling Policy
24	Warranty
25	Intellectual Property

Sorrento 2™

Basic Dimensions

A Overall Height*	Standard: 50" / 1270mm Range: 48"-54" / 1220mm-1370mm
B Back Height	Standard: 28" / 710mm Range: 26"-32" / 660mm-810mm
C Seat Height*	24" / 600mm
D Overall Length	49" / 1250mm

*Height measurements are based on 100mm castors.

Footplate Height Adjustments (from seat)

E High	15" / 380mm
F Low	20" / 510mm

Available Seat and Overall Widths

G (Seat Width)	H (Overall Width)
14" / 350mm*	25" / 660mm
16" / 400mm	25" / 660mm
18" / 450mm	26" / 670mm
20" / 500mm	28" / 720mm
22" / 550mm	30" / 770mm
24" / 600mm	32" / 820mm

* This seat width is achieved using a 400mm/16" seat width and a set of 25mm/1" padded arm covers.

Arm Height Options (from seat cushion)

I Low	6" / 160mm
J Medium	7" / 185mm
K High	8" / 210mm

Seat Depth

L	17 - 22" / 430mm - 550mm
---	--------------------------

Clearance Height

M	5" / 130mm*
---	-------------

*Height measurements are based on 100mm castors.

Full Recline Length

N	69" / 1750mm
---	--------------

Recline and Tilt Angles

ii Back Angle Recline

90° - 130°
40° range

iii Leg Rest Angle

80° - 150°
70° range

iv Tilt in Space

From 5° forward, or anterior, tilt to 30° or 45° backward tilt (dependent on chair model)

Chair Weight Unloaded

Motorised: 10 Stone / 64 Kg / 141 lb
Manual: 8 Stone / 51 Kg / 111 lb

Patient Weight Limit

31.5 Stone / 200 Kg / 440 lb

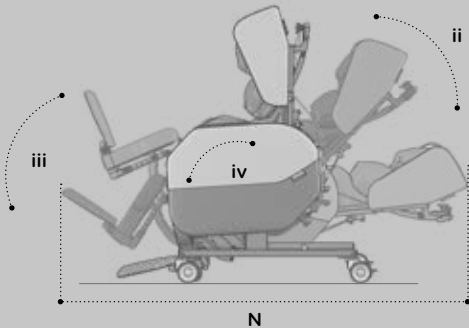
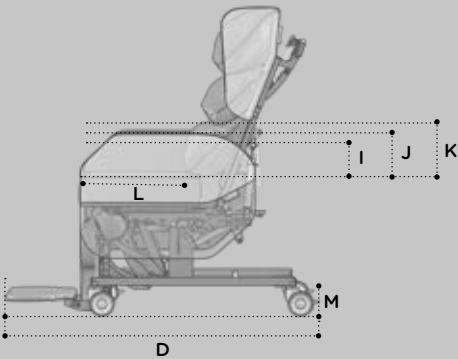
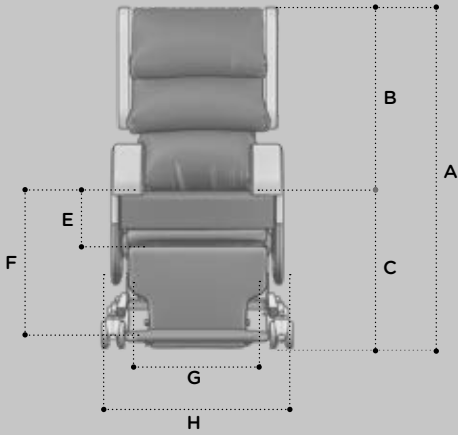



Tilt in Space (Manual Option)

For motorised option, see page 15.

To adjust the tilt angle of the chair (fig.1).

From the back of the chair, place both hands on the push handle and locate the **left** release lever (fig.1a) with your left hand. To tilt the chair, close your left hand pulling the lever towards you (fig.1b). With the lever engaged, tilt the chair to the required angle and release the lever again to lock the tilt in this position.



(fig.1a)



(fig.1b)



Back Angle Adjustment (Manual Option)

For motorised option, see page 15.

To adjust the back recline of the chair (fig.2).

From the back of the chair, place both hands on the push handle and locate the **right** release lever with your right hand (fig.2a). To recline the back of the chair, close your right hand pulling the lever towards you (fig.2b). With the lever engaged, recline the back to the required angle and release the lever again to lock the back in this position.



(fig.2)



(fig.2a)

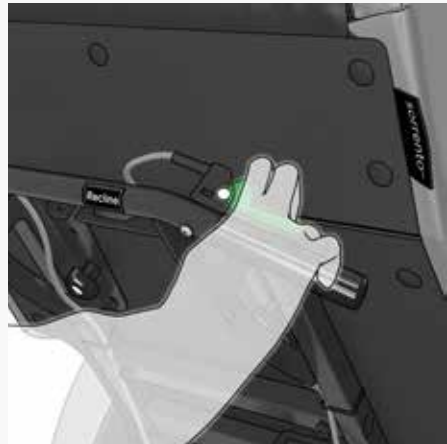

(fig.2b)



Leg Elevation (Manual Option)

For motorised option, see page 15.

To adjust the angle of legrest elevation (fig.3).

From the front of the chair, locate the leg rest lever attached to the right side base frame. **(fig.3a)** To elevate the leg rest, engage the release lever, pushing it downwards. **(fig.3b)** If adjusting the legrest elevation while the patient is in the chair, assist the elevation. To retract the leg rest, engage the release lever and pushing the leg rest assembly inwards.



(fig.3)

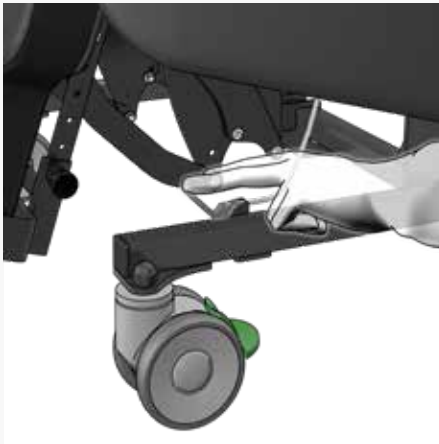

(fig.3a)

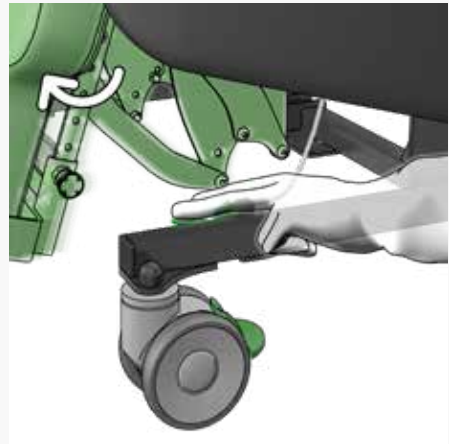

(fig.3b)



Back Height Adjustment

To adjust the back height of the chair (fig.4).

Remove left safety knob fully and loosen right adjustment knob so the back can slide freely (fig.4a). Loosen the sliding bolts if necessary. Slide the back up or down to the desired back height position, tighten the right adjustment knob then reattach and tighten the left safety knob (fig.4b).



(fig.4)

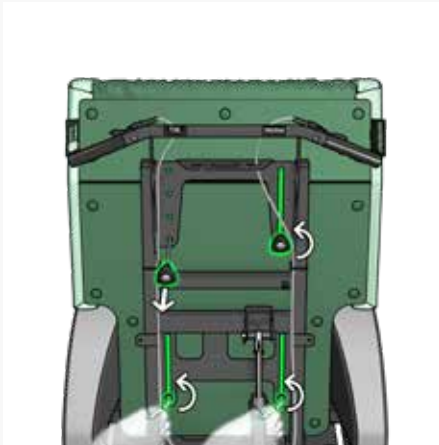

(fig.4a)

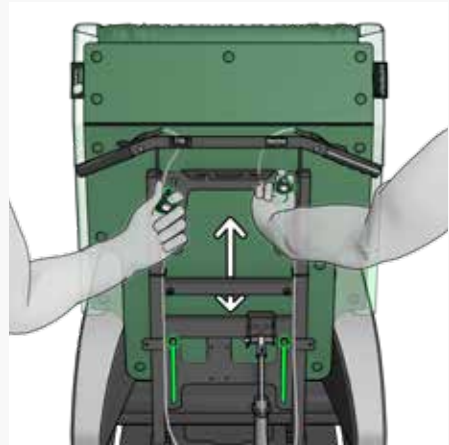

(fig.4b)



Seat Depth Adjustment

To adjust the seat depth of the chair (fig.5).

From the back of the chair, disengage the seat depth clamping lever by pushing it downwards (fig.5a). With your right hand disengage the seat depth safety plunger and push the seat base assembly forward or back to the required position (fig.5b). Ensure the safety pin locates to the desired position before re-engaging the seat depth clamping lever. The seat depth settings can be found below.



(fig.5)

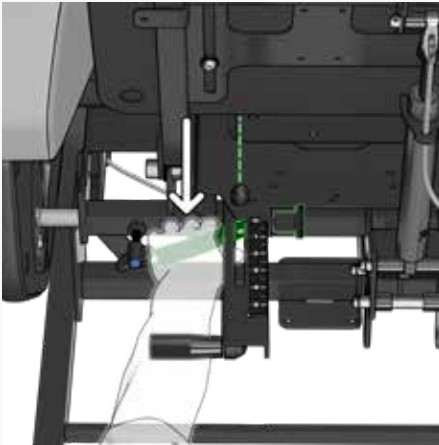

(fig.5a)

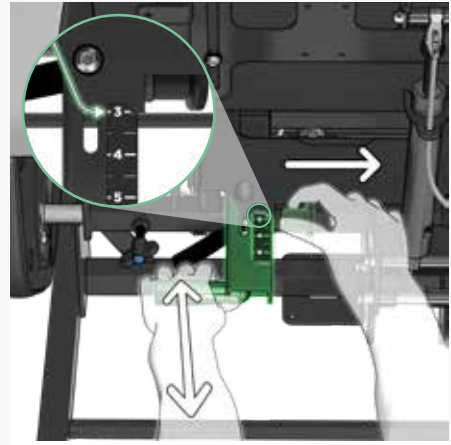

(fig.5b)

*There are six options for seat depth.

0	430mm 17"	1	450mm 18"	2	475mm 19"	3	500mm 20"	4	525mm 21"	5	550mm 22"
---	--------------	---	--------------	---	--------------	---	--------------	---	--------------	---	--------------



Seat Width Adjustment

To increase or decrease the seat width of the chair (fig.6).

From the back of the chair locate the **blue** wing knobs on the left and right of the seat frame, loosening them slightly. **(fig.6a)** Reposition the arms to the required position **(fig.6b)** and tighten both wing knobs to resecure.



(fig.6)

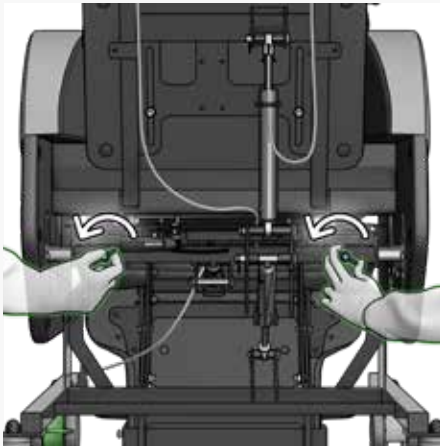

(fig.6a)

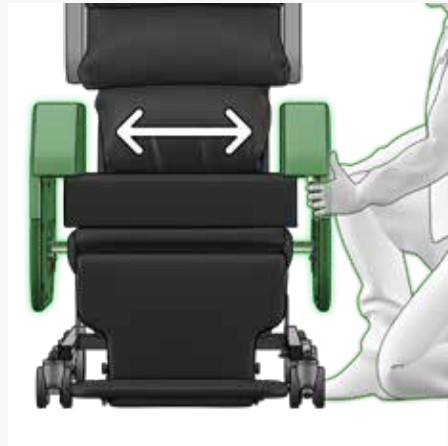

(fig.6b)



Arm Removal

To remove the arms of the chair (fig.7).

From the back of the chair locate the **blue** wing knob on the side of the arm you want to remove (**fig.7a**). Loosen the wing knob slightly. With the arm now free, remove it and set it in a safe place. Tighten the wing knob to resecure the arm.

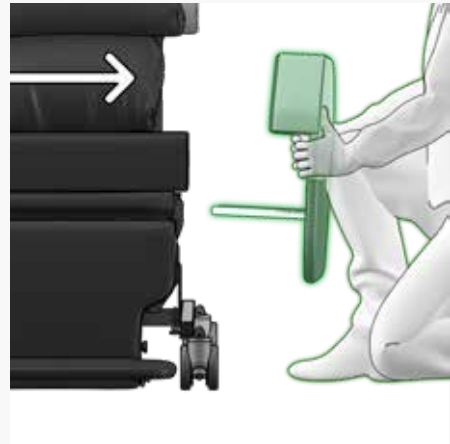
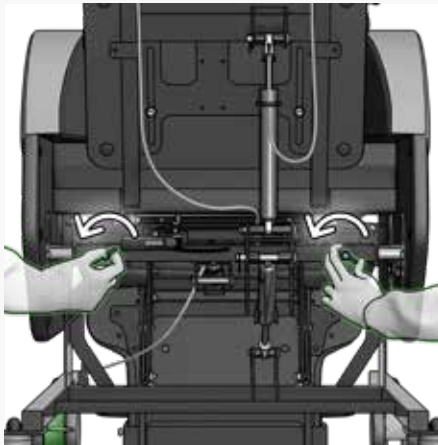



Arm Height Adjustment

To adjust the arm height of the chair (**fig.8**).

With the arm removed (**fig.8a**), using a 5mm allen key remove the safety bolts from the arm bracket. Loosen the sliding bolts if necessary. Slide the arm bracket to the desired position (**fig.8b**). Secure the safety bolts in place and tighten the sliding bolts. Tighten the wing knob to resecure the arm.

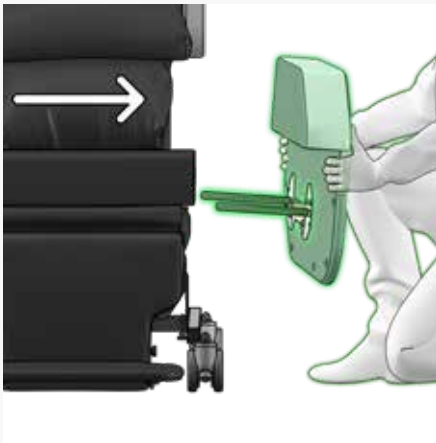

(fig.8a)

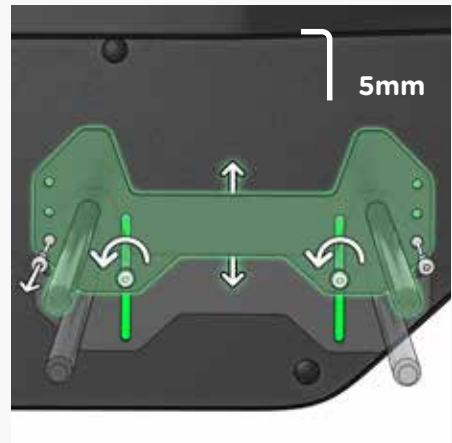

(fig.8b)



Footplate Height

To adjust the seat to footplate height of the chair (fig.9).

From the front of the chair, and with both hands, locate the two spring plungers at either side of the calf pad (fig.9a). Pull both spring plungers outward at the same time and move the footplate to the required position before releasing.

The pin of the spring plunger will locate to the nearest hole position and lock into place (fig.9b).

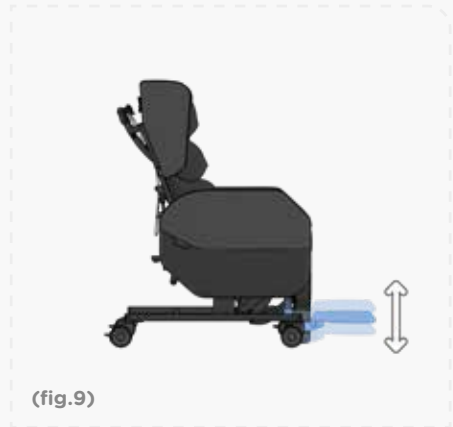

(fig.9)



(fig.9a)

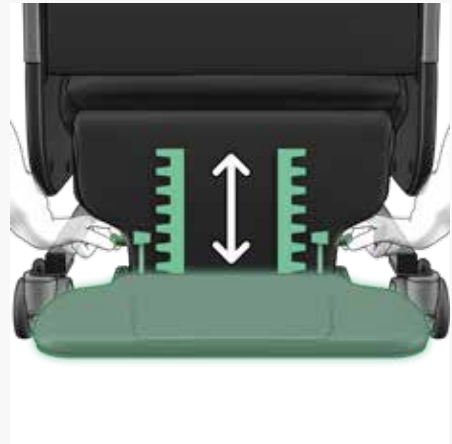

(fig.9b)



Footplate Angle

To adjust the angle of the footplate (fig.10).

Some tools are required to carry out this adjustment (fig.10a).

Using a 4mm allen key and 10mm spanner, loosen and remove the fixing bolt at either side of the footplate pivot (fig.10a). Relocate both bolts to the required setting (fig.10b) and tighten securely.

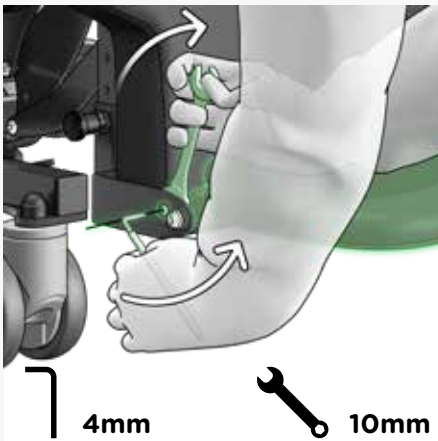
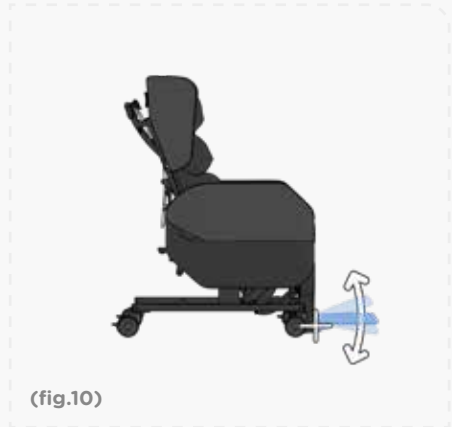

(fig.10a)

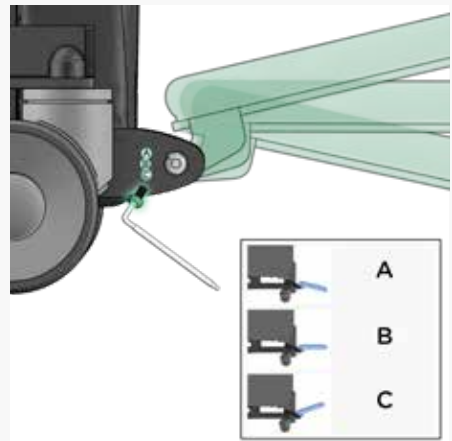

(fig.10b)



Seat Cushion

Removal and fitting of the modular Seating Matters cushion (fig.11).

The underside of the Seating Matters cushion and the baseboard of the chair are upholstered with non-slip material, which combine to create a friction contact when the chair is occupied. To fit the cushion correctly, place the cushion onto the baseboard of the chair, with the non-slip underside of the cushion facing downwards (fig.11a). The rear, zipped end of the cushion should be facing towards the back of the chair (fig.11b). See cushion label for orientation. To remove the cushion, simply lift it out from the chair.

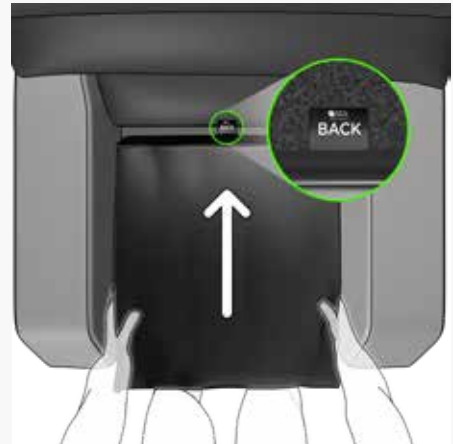

Correct fitment of the Seating Matters cushion is important as the structure of the foam allows good immersion ONLY when fitted as instructed above.

Chair Function (Motorised Option)

Fully Motorised Handset

If your chair is a **fully motorised model**, **Back Recline**, **Tilt in Space** and **Leg Elevation** are controlled by the handset.



Part Motorised Handset

If your chair is a **part motorised model**, **Tilt in Space** and **Leg Elevation** are controlled by the handset.



Charging Status

Monitor the charging status of your chair using the **Power lights** on the Handset (fig.12a).

Status lights are also located on the left side of the control box and battery (fig.12b).

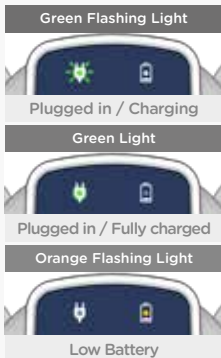

Handset (fig.12a)

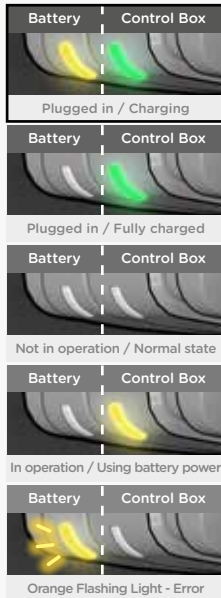

Control Box (fig.12b)

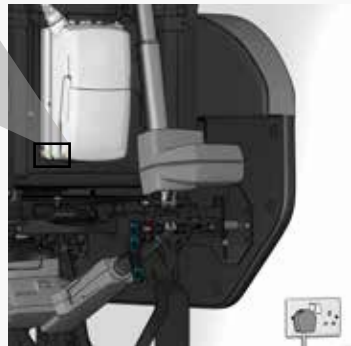

The buzzer will make a warning when a button on the hand control is pressed and the battery is low.



When error light shows switch off and unplug your chair immediately. Contact: technical@seatingmatters.com

Chair Function (Motorised Option)

Backrest Lock (Fully Motorised Only)

If your chair is a **fully motorised model**, the **Backrest** can be locked in position using the handset.



Lock/Unlock the Backrest

If the Backrest is unlocked, no lights will show above the Backrest buttons (fig.13a). Orange lights will indicate the Backrest is locked in position (fig.13c).

To **lock/unlock** the Backrest press and hold both Backrest buttons for 5 seconds (fig.13b).



Chair Function (Motorised Option)

Tilt Limit

The Maximum Tilt Limit can be set using the handset.

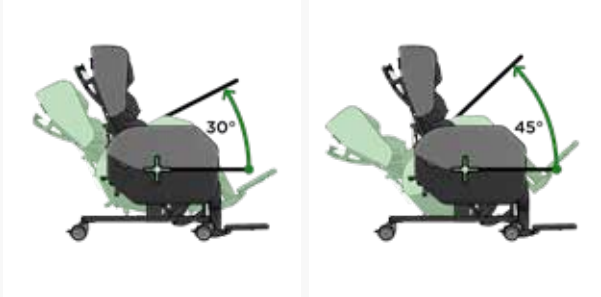

Set the Maximum Tilt Limit to 30° or 45°

To set the Tilt Limit press and hold the 30° or 45° button on the handset for 5 seconds (fig.14b). The orange light will indicate which setting is currently activated (fig.14a & fig.14c).



Chair Movement

Directional Lock Castor

For control of direction and manoeuvrability while pushing the chair (fig.13c).

The directional lock castor is located on the front left side of the chair (fig.13). To engage the directional lock castor simply press the green pedal with your foot (fig.13a) and swivel the castor until it clicks into the forward line (fig.13b).

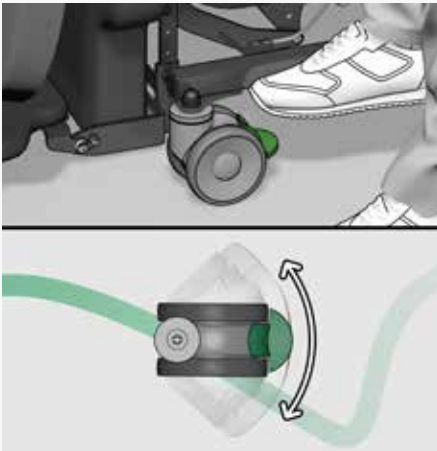

(fig.13a) Directional lock disengaged.

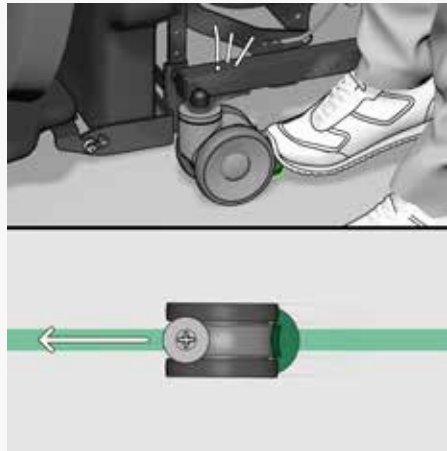

(fig.13b) Directional lock engaged.

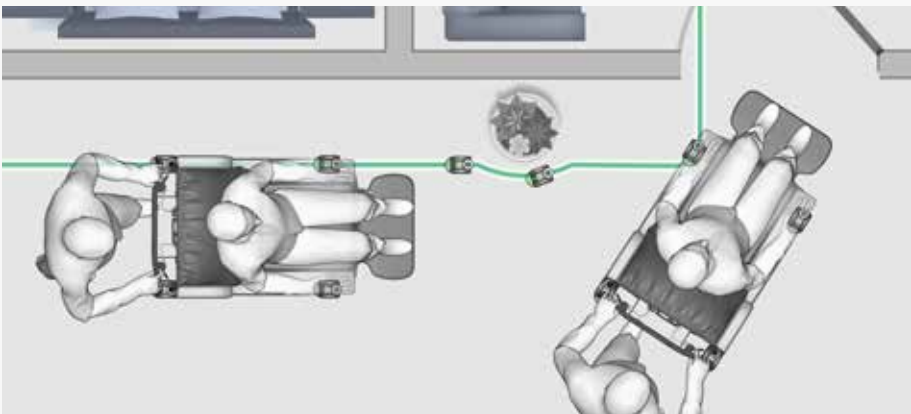

(fig.13c) Image showing use of the directional lock to improve manoeuvrability.

Braking Castors

To lock the chair in position (fig.14c).

Both rear castors on the chair are total lock castors (fig.14). When engaged, the swivel and rotation of the castor will be locked. To engage the braking castor simply press the pedal with your foot until it clicks in place (fig.14b).



(fig.14)

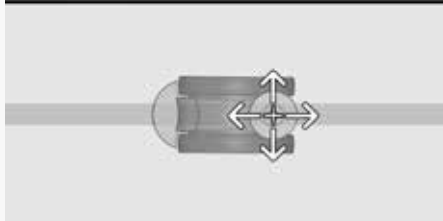

(fig.14a) All locks disengaged.



(fig.14b) Braking castors engaged.

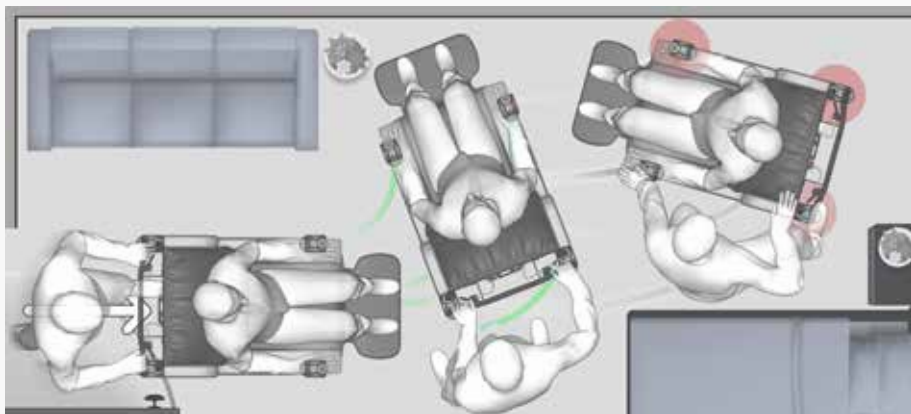

(fig.14c) Image showing chair in locked position.



Cleaning & Maintenance of Upholstery

Your Seating Matters chair is upholstered with two distinct materials, Vinyl and Dartex multi-stretch material. See image above for how to identify these on your chair.

Vinyl Properties

Vinyl is resistant to urine, most household stains, mild acids/alkalis, drinks and beverages as they are not absorbed and can be wiped off without any problem or lasting damage. Some difficult substances such as lipstick, ball point pen ink and food colourings should be cleaned off immediately to avoid permanent staining.

Dartex Multi Stretch Fabric Properties

Dartex is waterproof, has the ability to be wiped clean and has biostatic (anti-mycotic) coatings to provide an impenetrable barrier to virus and bacteria.

Cleaning

Superficial dirt may be removed by wiping with a soft cloth moistened with water containing a neutral detergent. More persistent contamination may be treated by wiping with alcohols or turpentine substitute, followed by hot water and detergent.

Routine cleaning and disinfection may be carried out on the coating with hand hot water and a neutral detergent or with a bleach solution (0.1% or 1000 parts per million available chlorine). The material is compatible with the 10,000ppm available chlorine in solution required for the decontamination of blood spills. Excess solution must be removed and the surface thoroughly rinsed and dried prior to reuse or storage.

Proprietary disinfectants may be used provided manufacturer's instructions are followed.

All cleaning agents, and disinfectants, must be thoroughly rinsed off and the item dried after cleaning.

What you can use:

1. Warm Soapy Water	Use warm soapy water to wash down your chair. Bear in mind that it is important to dry the surface afterwards.
2. 70% Alcohol	This can be used in line with the manufacturer's guidelines.
3. Bleach	Concentrations of bleach from 1,000ppm to 10,000ppm available chlorine, is likely to be considered effective cleaning. Use bleach sparingly.

Example of Dilution Ratio

The ppm of available chlorine may vary with each different brand of bleach.

Search online for its data sheet and adjust your ratio accordingly to achieve a dilution of approx. 1000ppm of available chlorine.



Water



Bleach

For an in-depth guide to cleaning, please consult our Clinicians Guide to Infection Control, available on our website.



Assembly, Installation, Warnings & Hazards

- ① A competent person, or User, trained in the use of the chair, who is either a suitably qualified medical professional, or is working under their guidance and instruction, should make adjustments and set up the product according to the Patient requirements and dimensions before the Patient sits in the chair. Where possible, adjustments should be made when the Patient is not in the chair to avoid injury to the User and Patient.
- ② This product, and its accessories, should be used in accordance with local or regional guidelines regarding the use of such medical devices.
- ③ This chair should be fully assembled, all fixings secured and the chair checked for safety by a competent person before use.
- ④ The User must ensure that the product is in good condition before use (check all nuts and bolts are fastened, fabric in good condition etc). If there are any problems, these must be reported to your Seating Matters provider and corrected before the chair is put into use.
- ⑤ Keep all body parts away from the mechanisms under the chair. Repairs and maintenance should only be carried out by fully trained technicians.
- ⑥ Exercise care in using the release lever for the reclining mechanisms and adjustments to avoid injury.
- ⑦ Pressure ulcer or pressure injury reduction is not a guarantee with this equipment. The User must ensure that the Patient has a period out of the chair after prolonged sitting to raise tissue oxygenation levels. Although the chair offers pressure management, the body tissue still needs time to recover. In many places, local or national guidelines recommend a maximum of 2 hours sitting at any one time. You must also observe Patient specific recommendations and guidelines as set by their health professional with regard to the use of tilt and recline for appropriate pressure management.
- ⑧ The product must be used on a level, plain, hard surface with the brakes engaged to avoid it moving during use and to ensure stability. When the chair is not in transit, all the braking castors on the product must be engaged to prevent risk of injury when being used.
- ⑨ The product may not be left in an outdoor environment. More information on fabrics and their environment can be found later in this manual.
- ⑩ Ensure there is more than one competent person there when making adjustments to ensure they are correct and safe for the Patient.
- ⑪ If in doubt as to any the adjustments, feel free to contact Seating Matters direct at technical@seatingmatters.com.
- ⑫ Under no circumstances must the User or Patient stand or sit on the footplate of the chair.
- ⑬ The chair should not be transported in a vehicle while the Patient is seated on the chair.
- ⑭ This product should not be lifted at any time unless by competent persons trained in such manual handling.
- ⑮ When operating the leg rest and recline features on the chair please ensure there is a 450mm / 18" gap around the chair to prevent the back or leg rest coming into contact with a wall or any other object.
- ⑯ On powered options, please ensure that your chair is charged daily.

Please call your Seating Matters provider if you have any questions on these points.

Regularly servicing your Seating Matters chair will prevent untimely and inconvenient breakdowns, reduce repair costs and extend the chair's working life. Damage to the chair can also cause excess strain for the User and Patient.

Important

Parts can only be changed by service persons trained in Seating Matters products and use only Seating Matters parts. We recommend that your chair is serviced every year by a Seating Matters approved provider for any running repairs and maintenance.

Maintenance

Carry out the following regular checks to ensure the operation and safety of the chair. If you are in any doubt about the functioning of your chair contact your Seating Matters approved provider immediately.

Daily

- 1 Check that the castors are not damaged.
- 2 Check that the castors turn freely.
- 3 Make sure that the castor forks run free and are not bent.
- 4 Check all fabrics for damage or contamination and replace where necessary.
- 5 See Cleaning Instructions section in the manual for cleaning instructions.
- 6 Check batteries and electrical connections are secure.

Weekly

- 1 Check the castor fittings for hair and dirt etc. which could restrict the castor movement.
- 2 Pick out any such material with tweezers or take the spindle out, clean it and then replace it.
- 3 If it is still not free (one continuous turn without it sticking) contact your Seating Matters approved provider for a replacement.

Monthly

Castors

Make sure the top of the castor housing is parallel with the floor. Any variation will cause restricted movement. If it is damaged contact your Seating Matters approved provider for a replacement.

Mechanisms

Check all tilting mechanisms are working smoothly.

Check that cables are not kinked or frayed.

Check that all nuts and bolts are present.

Check that all nuts and bolts are secure.

Note: If nuts or bolts need attention, contact your Seating Matters approved provider IMMEDIATELY and DO NOT USE the chair until it has been serviced.

Leg Rest

Check that all leg rests are easily removed/swung-away and replaced or repositioned easily. Ensure that parts lock in place securely. If parts are not locking try lubricating. If the problem still remains contact your Seating Matters approved provider.

Frame

Check the visible parts of the frame for cracks, splits, large dents or other damage. If you find any of these things DO NOT USE. Contact your Seating Matters approved provider immediately.

Seating Matters are committed to reducing waste and improving our care for the environment. Where possible we have manufactured our chairs with recyclable materials. Guidance on recycling can be found below.

The WEEE Directive

The WEEE Directive, 2012/19/EC, urges producers of Electrical and Electronic Equipment (EEE) to provide information on how these products can be treated, reused or recycled.

In order to comply with this directive in the European Union, Seating Matters electrical components are marked with a crossed out wheellie bin. This indicates that the electrical components should be treated in accordance with the WEEE regulations after their useful life.

Advice on Recycling

- 1 Your Seating Matters chair may contain batteries which should not be disposed of in household waste.
- 2 Never dispose of the battery in a fire. This may cause an explosion.
- 3 The chair may contain substances that could be harmful to the environment.
- 4 Electrical components must be taken to a proper recycling facility.
- 5 Your Seating Matters chair contains component parts which can be recycled.
- 6 We thank you for being environmentally responsible and for making efforts to recycle your Seating Matters chair at the end of its' safe and useful life.
- 7 Contact your local authority or governmental agency for the regulations that apply in your area.
- 8 If you wish to have Seating Matters recycle your chair on your behalf, you are welcome to return the product to our company.



Plastic Components

Many of our plastic components are made from polypropylene and can be recycled as long as they are recycled with other polypropylene resin materials. Polypropylene sheets can be recycled with any other materials that have this symbol.



Plastic Trays

Our plastic tray tables are made from Polyethylene Terephthalate Glycol (PETG) which is a sturdy, transparent, easily cleaned material. Like acrylic, PETG is 100% recyclable and can be recycled and re-purposed indefinitely. Capable of being sterilized, it's a renowned food-safe material and will help us meet a higher standard towards infection prevention & control. PETG's damage resistance is far higher than that of acrylic & has an impact resistance 30 times that of glass. PETG can be recycled with any other materials that have this symbol.



Safety

The Sorrento 2™ is CE marked to show conformance to the Medical Devices Directive 93/42/EEC and conforms to BS ISO 7176 at medium hazard.

Regional Variations

The device referred to as a "Sorrento 2™" is a Seating Matters product category and the information included in this document reflects common features of this group of products. In some regions of the world, we supply product design variations of equivalent function and ease-of-use but with alternative specifications or reinforcements.

The following table outlines the parts covered under frame warranty and the warranty period specific to your chair;

Chair	Frame Warranty Period	Frame Parts Covered
Adult Phoenix & Sorrento	7 Years	(a) Metal base frame. (b) Metal seat frame. (c) Metal back rest frame. (d) Armrest brackets. (e) Cracks or tears in metal work. (f) Leg rest linkages. (g) All mounting points for gas struts and electric actuators. (h) All metal fixings and hinges. (i) All welds on chair frame.
Kids Phoenix & Sorrento		
Bariatric Sorrento		
Atlanta		
Monaco		
Adult Phoenix 2 & Sorrento 2	3 Years	
Milano		
Sydney GoFlat		
Denver	1 Year	

The following table outlines the parts covered under components warranty;

Chair	Component Warranty Period	Components Covered
Adult Phoenix & Sorrento	1 Year	(a) Actuator systems including control box, handset and charger/charger lead. (b) Gas struts including release cables and component parts. (c) Upholstery if there is a clear and obvious manufacturing error. (d) Castors. (e) Wing knobs and adjustment handles. (f) Bolts and attachment fixings.
Kids Phoenix & Sorrento		
Bariatric Sorrento		
Atlanta		
Monaco		
Adult Phoenix 2 & Sorrento 2		
Milano		
Sydney GoFlat		
Denver		

For full terms and conditions visit our website or scan the QR code here:



Seating Matters are at the forefront of seating research and design, therefore we take the protection of our intellectual property very seriously and have our designs, patents and trademarks protected in many jurisdictions throughout the world.

The Seating Matters Trademark is registered throughout the European Union and various countries globally.

Patent Pending No. GB1915470.7

US Design Patent No. 601360S
No. D611718
No. 600932
No. D602704S

Australian Design Registration No. 325536
No. 324011
No. 325537
No. 324012

Community Design Registration No. 001016364-002
No. 000942180-0004
No. 002428813-0001
No. 001016364-001
No. 012673018

Canadian Design Registration No. 130224
No. 128763
No. 130217
No. 128764

We are here to help

For any questions or queries regarding your Seating Matters chair please contact: contact@seatingmatters.com



Australia

9/256 New Line Road
Dural
NSW 2158
Australia
T: +61 1300 001 050
info@seatingmatters.com.au

USA

300 International Dr
Suite 100, Buffalo
New York, USA
NY 14221
T: +1 (905) 507 9007
usa@seatingmatters.com

UK & Europe

131 Carnamuff Road
Limavady
Northern Ireland
BT49 9JG
T: +44 (0) 28 777 666 24
contact@seatingmatters.com